

Technical Regulations for GT4 Grand Touring Cars - DUTCH GT4 Championship 2009 -

ARTICLE 1 : DEFINITIONS

1.1 Bodywork

All entirely sprung parts of the car in contact with the external air stream, except the parts definitely associated with the mechanical functioning of the engine, transmission and running gear.
Any air intake shall be considered to be part of the bodywork.

1.2 Original

As fitted to the SRO Motorsports Group-approved series-produced car and in compliance with their Technical Form.

1.3 Event

An event shall consist of official practice and the race(s).

1.4 Weight

Is the weight of the car without the driver at any time during the event and its eventual ballast.

1.5 Racing weight

Is the weight of the car in running order with the driver aboard and the quantity of fuel in its tank.

1.6 Wheel

Wheel: Flange and rim.

Complete wheel: Flange, rim and tyre.

1.7 Cockpit

Closed car : The interior volume of the main structure which is reserved for the occupants.

Its limits are defined by the roof, the floor, the doors, the lateral parts, the glazed parts and the front and rear bulkheads.

Open car : The cockpit opening must be symmetrical as viewed from above, and nothing is permitted to cover it except for a hood or a hard-top.

1.8 Supercharging

Increasing the weight of the charge of the fuel/air mixture in the combustion chamber (over the weight induced by normal atmospheric pressure, ram effect and dynamic effects in the intake and/or exhaust system) by any means whatsoever.

The injection of fuel under pressure is not considered to be supercharging.

1.9 Semi-automatic gearbox

One which, when the driver calls for a gear change, takes over the control of one or more of the engine, clutch and gear selectors momentarily to enable the gear to be engaged.

1.10 Location

A site defined relative to the original: centre line of the car, axles centre (middle of the wheelbase on the centre line), cockpit, luggage compartment and engine compartment.

Location within the engine compartment is a site defined relative to the crank case and cylinder head(s).

1.11 Position

The site defined by dimensions from the original vehicle data, e.g. axles centre and centre line of the car.

1.12 Orientation

Is the relationship of the component to the longitudinal and transversal axes of the vehicle. If the component is turned 180°, this will be regarded as a change in orientation.

1.13 Telemetry

The transmission of data between a moving car and anyone connected with the entry of that car.

ARTICLE 2 : REGULATIONS

2.1 Role of the SRO

The following technical regulations for the GT4 type Grand Touring Cars are issued by SRO Motorsports Group.

2.2 Vehicle type eligibility

Vehicles will be eligible in the GT4 Grand Touring class.

For a vehicle to be eligible in the GT4 type Grand Touring class, it must be a car approved by SRO Motorsports Group and homologated by the RACB in GT4.

2.3 Eligible cars

The list of approved cars will be published by SRO Motorsports Group.

2.4 Regulation and eligibility amendments

SRO Motorsports Group will publish any changes made to these regulations. All such changes will come into effect after their publication by the ASN.

Changes for safety reasons may be made without notice.

2.5 Compliance with the regulations

The car entered by a competitor must conform strictly to its Technical Form as well as to any additional notification from the Bureau of the SRO/Dutch GT4.

It is the duty of each competitor to satisfy the Scrutineers and the Stewards of the Meeting that his car complies with these regulations in their entirety at all times during an event.

A car, the construction of which is deemed to be dangerous, may be excluded by the Stewards of the meeting.

2.6 Measurements

All measurements must be taken while the car is stationary on a flat horizontal surface or as stated in the Sporting Regulations of the relevant Series.

2.7 Material

Titanium is not permitted unless used in the original part or explicitly authorised by these regulations.

The use of a material which has a specific yield modulus greater than 40 GPa/g/cm³ is forbidden for the making of all parts that are free or homologated as an Option Variant.

This restriction does not concern the parts homologated with the standard vehicle.

The use of magnesium sheet less than 3 mm thick is forbidden.

2.8 Data logging

A data acquisition system homologated by SRO Motorsports Group and the DUTCH GT4 organisation is mandatory.

The installation of this system must be made in strict accordance with the corresponding instructions and must work at all times during the Event. All competitors are themselves responsible for obtaining the system, for the correct installation and the correct functioning thereof.

The data logging system must be able to provide at least the following data:

- Speed of the 4 wheels (failing that, of one front wheel and one rear wheel)
- Longitudinal acceleration
- Lateral acceleration
- Accelerator position

The data thus collected must remain at the disposal of the Bureau of the SRO/ Dutch GT4 and / or the DUTCH GT4 organisation.

2.9 Telemetry

The use of telemetry is forbidden.

ARTICLE 3 : BODYWORK

3.1 Bodywork

All bodywork dimensions and shape must remain original, as available by the Manufacturer.

The front and rear overhangs must remain original.

Material used for the bonnet and boot lids, bumpers, doors and wings must remain original or as described on the technical form of the car, unless by a waiver of the Bureau of the SRO GT4. Where an element is replaced, it must be attached in a way which is at least as strong as the original method and any non moveable element shall be attached with the use of tools.

3.1.1) Bonnet and boot lids

They must have at least two safety fasteners, both of which are clearly indicated by red (or contrasting colour) arrows.

It must be possible to remove or open them without the use of tools. A waiver by the SRO Technical Department can be given for special constructions.

3.1.2) All bodywork joints in the vicinity of the refuelling connections must be designed in such a way as to prevent any leakage of fuel into the engine compartment and/or cockpit during refuelling.

3.2 Windscreen and windows

A windscreen made of one piece of laminated glass, or polycarbonate (the thickness must not be less than 6 mm), is compulsory.

In order to protect the windscreen, the addition of a maximum of 4 translucent films on its external face is permitted.

Additional fastenings may be used for securing the windscreen.

The side and rear windows may be replaced with polycarbonate.

Onto the inside surface of the side windows in glass, a colourless and translucent anti-shatter film (such as SL Lumar Safety Film/D1570) of 0.1 mm maximum must be installed, in order to guarantee an appropriate protection in case of splintering.

Cockpit ventilation:

In order to extract air from the cockpit, the rear window may have a maximum of 5 circular holes with a maximum diameter of 50 mm each.

A cut-out of a maximum surface of 25 cm² is authorised in each rear view mirror.

A scoop may be fitted to each door window, provided that it complies with the following points:

- it must not exceed the perimeter of the window, must have a maximum height of 150 mm and must not protrude more than 50 mm over the window's surface.

- it must be made from the same material as the window or from translucent polycarbonate if the window is made from glass, and must be able to be closed by a shutter made from the same material as the window.

- it must not obstruct the driver's rearward view.

Air ducts fed by the scoops are authorised inside the cockpit on condition that they reduce neither the visibility nor the safety of the driver.

Nets:

Nets are mandatory on the driver site of the car. The nets must have the characteristics in accordance with Article 253-11.

The net must be attached either to the safety cage or to a fixed part of the bodywork, above the driver's window, by means of a rapid release system that will function even if the car turns over.

It must be possible to detach the net with one hand.

To this end, the handle or lever must have coloured markings ("dayglo" orange).

A push-button release system is authorised provided that it respects the prescriptions of this article.

The push-buttons must be visible from the outside, be of a contrasting colour and be marked "press".

Each rear side window may be partly opened to a maximum of 30 mm at its rear extremity, or may have a circular opening with a maximum diameter of 50 mm.

3.3 Aerodynamic devices

Forbidden, unless original or by a waiver of the Bureau of the SRO GT4.

ARTICLE 4 : WEIGHT

4.1 Minimum weight

The weight of the car must not be less than 1000 kg in GT4.

The Bureau of the SRO/ Dutch GT4 reserves the right to adjust the minimum weight of any car in order to maintain the balance of performance between the cars. The minimum weight must be respected at all times during the event, in particular when the car crosses the finish line. It is permitted to complete the weight of the car by one or several units of ballast before initial scrutineering.

4.2 Ballast

Ballast must be secured in the cockpit in the passenger's location and according to the specifications of Article 253-16 concerning the dimensions and characteristics of the fixations.

The securing system must allow seals to be affixed to the ballast by the scrutineers and must be designed such that tools are required for its removal.

Any movable ballast system when the car is in motion is forbidden.

4.3 Levelling / Success Ballast

The levelling / succes ballast (only the weight of the stacking metallic plates) must, in addition to the requirements of Article 4.2, comply with the following points:

- It must be made from stacking metallic plates according to Drawing n° 258-2,
- The plates must be firmly attached inside a housing by means of 5 M12 screws.

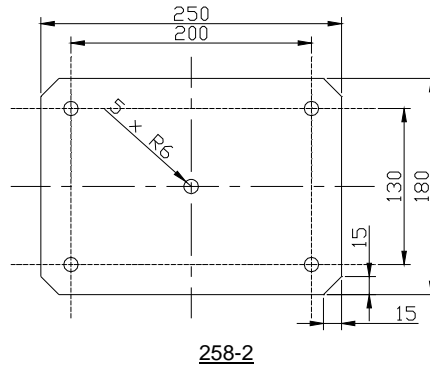

4.4 Adding during the race

The adding to the car during the race of any solid material whatsoever, and the replacement during the race of any part of the car with another which is materially heavier, are forbidden.

4.5 Liquids

The weight may be checked at any time during the event with the quantity of liquids remaining in the tanks, except after the race when the car may be emptied of all the fuel before weighing.

ARTICLE 5 : ENGINE

5.1 Type and position of engine

The make and type of engine used must remain original.

The position of the engine, the location and orientation must remain original.

5.2 Engine control unit

The Dutch GT4 Technical Delegate may at any time oblige the competitor to use the reference unit registered with the SRO Motorsports Group by the Manufacturer or Tuner.

5.3 Intake system

5.3.1) The intake system is defined by the assembly comprising the restrictor(s) (if applicable) and the manifold up to the intake ports on the cylinder head(s).

5.3.2) All the air feeding the engine must pass through the homologated air restrictors (if applicable), and no pipe containing air is permitted to enter or to exit from the intake system.

The restrictor(s) must be made of metal or metal alloy, 3 mm long and must be entirely visible once the bonnet is open and without dismounting any element or cover.

Sealing the restrictors must cause the engine to stop immediately.

This check must be carried out at an engine speed of 2500 rpm, the pressure sensors present inside the intake system being disconnected.

The depression measured in the intake system when the engine stops must be at least equal to the atmospheric pressure in the place where the check is carried out minus 150 millibar, maintained during at least 0.5 seconds.

5.3.3) The Bureau of the SRO/Dutch GT4 reserves the right to adjust the diameter of these air restrictors (if applicable) in order to maintain the balance of performance between the cars.

5.4 Exhaust

5.4.1) The exhaust system should incorporate one or more homologated catalytic converters, which should be functioning at all times and through which all exhaust gases should pass.

5.4.2) The noise generated by the car must not exceed 92 dB (A)

This measurement will be taken at the official measurement point located in the Bos Uit Corner at the Circuit Park Zandvoort with the official equipment or other official equipment at other tracks on the race calendar of the DUTCH GT4 Championship

All measures taken to ensure that the maximum noise limits are not exceeded must be permanent in nature, and must not be cancelled out by the exhaust gas pressure.

5.4.3) The exit of the exhaust pipe must be situated at the rear of the car, at a minimum of 100 mm from the ground. Exhaust gas may only exit at the end of the system. Parts of the chassis must not be used to evacuate exhaust gases.

ARTICLE 6 : FUEL SYSTEM, REFUELLING

6.1 Refuelling during the race
Not applicable.

6.2 Fuel capacity

The capacity of the fuel tanks must be big enough for cars to race an hour.

The Bureau of the SRO/Dutch GT4 reserves the right to adjust the capacity of the fuel tank in order to maintain the balance of performance between the cars.

6.3 Fuel tanks

All fuel tanks must be standard or rubber bladders conforming to or exceeding the specifications of FIA/FT3 1999, and must comply with the prescriptions of Article 253-14. They must be placed in the original location or in the luggage compartment.

6.4 Piping

All fuel lines must comply with the specifications of Article 253-3.

6.5 Fuel samples

All cars must be fitted with a self-sealing connector which can be used by the Scrutineers to obtain samples of the fuel feeding the engine.

This connector must be of the type approved by the FIA.

ARTICLE 7 : LUBRICATION SYSTEM

7.1 Catch tank

When a car's lubrication system includes an open type sump breather, it must vent into a catch tank of at least 3 litres capacity fitted with a visible level gauge.

ARTICLE 8 : ELECTRICAL EQUIPMENT

8.1 Battery

Batteries may be situated in the cockpit but without obstructing the exit of the driver.

Batteries must be securely fixed to the body shell and completely surrounded by a box made of insulating material that includes an air vent which exits outside the cockpit.

If the battery situated in the cockpit is a dry battery, it must be protected electrically by a cover which covers it completely.

The attachment to the body shell must consist of a metal seat and two metal clamps, with an insulating covering, fixed to the floor by bolts and nuts.

For attaching these clamps, bolts with a diameter of at least 10 mm must be used, and under each bolt, a counterplate at least 3 mm thick and with a surface of at least 20 cm² beneath the metal of the bodywork (see Drawings 255-10 and 255-11).

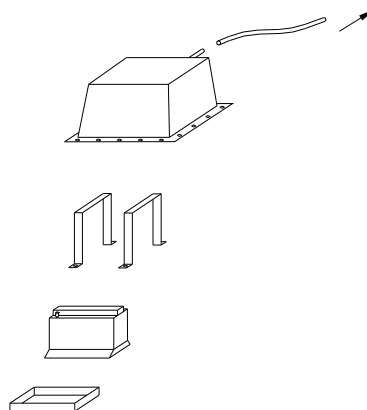

255-10

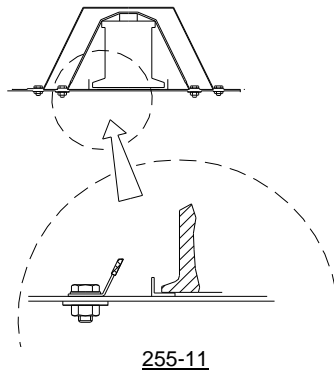

8.2 Windscreen wiper

The car must be fitted with the original windscreen wiper system, which must be in working order throughout the event. Only the blades may be replaced. The capacity of the windscreen washer tank may be modified.

8.3 Starting

A starter must be fitted and be in working order at all times during an event. The driver must also be able to operate the starter when seated normally.

8.4 Lighting equipment

8.4.1) All lighting equipment must be in working order throughout the event.

8.4.2) The exterior lighting equipment must at least ensure the following functions : Headlights, direction indicators, stop lights, rain light (see 8.4.4) and rear sidelights. For safety reasons, it is obligatory for headlights to produce a white beam. For races run in the daytime, GT4 cars must be equipped with white headlight covers. For races run at night, the front bumper may be modified to accommodate supplementary lighting. These modifications must not create any aerodynamic downforce.

8.4.3) Reversing lights:

The bulbs of the reversing lights must be removed.

8.4.4) Rain lights:

All cars must have a red light of at least 21 watts, in working order throughout the event, which:

- is a model approved by the FIA, or an original third stoplight
 - faces rearwards at 90° to the car centre line,
 - is clearly visible from the rear,
 - is mounted not more than 10 cm from the car centre line,
 - is at least 35 cm above the reference plane,
 - is at least 45 cm behind the rear wheel centre line, measured to the face of the lens and parallel to the reference plane, or as on the series-produced car,
 - can be switched on by the driver when seated normally in the car,
- The three measurements are taken to the centre of area of the lens.

ARTICLE 9 : TRANSMISSION

9.1 Transmission system

The gearbox must comprise a maximum of 6 ratios and a reverse gear. The interior of the gearbox is free. The number of teeth and ratios homologated in the Technical Form must be retained. The joints of the gearbox are free. The gear selection grid pattern homologated on the series model must be retained.

Sequential gearboxes are forbidden in GT4.

For cars fitted with a semi-automatic or automatic gearbox, and/or a power-driven clutch with electronic or pneumatic control, a waiver of the Bureau of the SRO/Dutch GT4 can eventual be granted. By this the Dutch GT4 Technical Delegate may at any time oblige the competitor to use the reference unit(s) registered with the SRO Motorsports Group by the manufacturer or tuner.

For safety reasons, the transmission must be designed in such a way that if the car is stopped and the engine is stalled, it is possible to push or tow it.

9.2 Reverse gear

All cars must have a reverse gear which, at any time during the event, can be selected while the engine is running and be used by the driver when seated normally.

ARTICLE 10 : AXLES, SUSPENSION AND STEERING

10.1 Ride height

The Bureau of the SRO/Dutch GT4 reserves the right to adjust the ride height in order to maintain the balance of performance between the cars.

For the checking of the ride height, the pressure of the tyres must not be less than 1.5 bars.

10.2 Suspension type and mounting

10.2.1) All suspension components, with the exception of parts specifically mentioned below, must be original equipment supplied by the manufacturer and comply with the Technical Form.

10.2.2) The position of the suspension and the steering box (rack or other) anchorage points on the chassis must be as original.

10.2.3) The addition of an anti-roll bar (adjustable or not) is permitted.

10.2.4) Shock absorbers are mentioned in the Technical Form and must comply with it. The working principle (adjustable or not) is free. A maximum of 3 spring sets (front/rear) can be homologated. The shock absorber reservoir and its possible line must be completely isolated from the cockpit or covered and may not be located in a compartment giving access to the ventilation system of the car. No electrical, hydraulic or pneumatic connection between the shock absorbers is permitted. The modification of spring, shock absorber and anti-roll bars adjustments from the cockpit is prohibited.

10.2 Steering

The steering lock must be dismantled and the column adjusting system must be locked. The steering wheel may be fitted with a quick release system. The shape of the steering wheel must be round. The quick release mechanism must consist of a flange concentric to the steering wheel axis, coloured yellow through anodizing or any other durable yellow coating, and installed on the steering column behind the steering wheel. The release must be operated by pulling the flange along the steering wheel axis.

10.3 Power steering

For cars fitted with an automatically variable power steering, the Dutch GT4 Technical Delegate may at any time oblige the competitor to use the reference unit registered with the SRO Motorsports Group by the manufacturer or tuner.

ARTICLE 11 : BRAKES

11.1 Hydraulic circuits and tanks

The complete braking system must incorporate at least two separate circuits operated by the same pedal. This system must be designed so that if leakage or failure occurs in one circuit, the pedal shall still operate the brakes on at least two wheels. The brake fluid tanks may be fixed inside the cockpit, on condition that they are securely fastened and protected. The balance of the braking forces between the front and rear axles may (if homologated) be adjusted by the driver, through:
 - a direct and manual intervention on a mechanical system allowing the modification of the position of the centre of the joint, on the linkage lever of the hydraulic pumps of the front and rear circuits, mounted on the original pedal unit.
 - a direct and manual intervention on a proportional valve, in which the intake pressure of the rear circuit is adjusted through a pre-loaded spring, variable according to the position of the manual linkage system (see the Drawing of the principle 263-9).

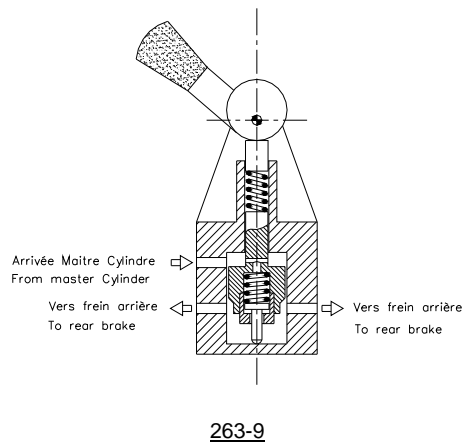

Only one of these two systems is permitted.

11.2 Anti-lock braking and power braking

For cars fitted with anti-lock and/or automatically variable power braking systems, the Dutch GT4 Technical Delegate may at any time oblige the competitor to use the reference unit registered with the SRO Motorsports Group by the manufacturer or tuner.

11.3 Cooling of brakes

Only one flexible pipe to bring the air to the brakes of each wheel is allowed, but its inside section must be able to fit into a circle with a 10 cm diameter. This pipe may be doubled, but in that case the inside section of each pipe must be able to fit into a circle with a 76 mm (3") diameter. The air pipes must not go beyond the perimeter of the car, seen from above.

ARTICLE 12 : WHEELS AND TYRES

12.1 Dimensions

The maximum authorised diameter of the rims is 18 inches. Maximum width : 11 inches. The Bureau of the SRO/Dutch GT4 reserves the right to adjust the width of the complete wheels in order to maintain the balance of performance between the cars. Measurements will be taken horizontally at axle centre line height.

12.2 Wheel visibility

The complete wheel above the hub centre line must not be visible in plan view and when viewed from the front, with the wheels aligned for the car to proceed straight ahead.

12.3 Wheel attachment

Wheels fixations by bolts may be changed to fixations by pins and nuts provided that the number of attachment points and the diameter of the threaded parts as indicated on Drawing 254-1 are respected.

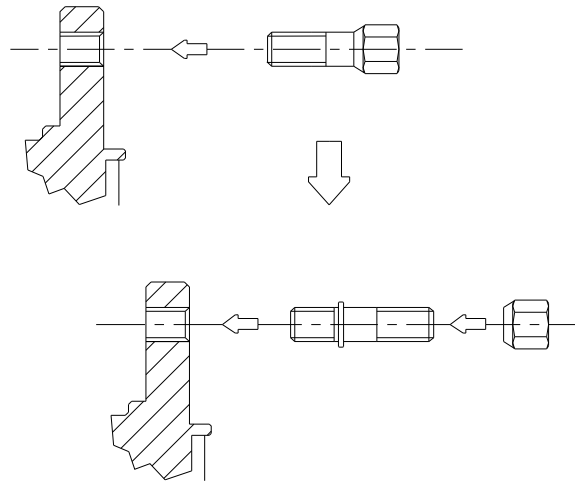

254-1

The wheel nuts may be changed, provided that their material remains ferrous.
Air extractors added on the wheels are forbidden.

12.4 Pressure control valves

Pressure control valves on the wheels are forbidden.

12.5 Sensors

Sensors for measuring the pressure and the temperature of the tyres when the car is in motion are strongly recommended.
If these sensors are used, there must be at least one warning light to notify the driver of a probable failure.

12.6 Pneumatic jacks

Pneumatic jacks may be fitted to the car, but compressed air bottles are not to be carried on board.

ARTICLE 13 : COCKPIT

13.1 Equipment permitted in the cockpit

13.1.1) The only components which can be added in the cockpit are:

- Safety equipment and structures
- Tool kit
- Seat, instruments and any other controls necessary for driving including the brake power distributor switch
- Electronic and electrical equipment
- Inboard camera system
- Driver cooling system
- Ballast
- Pneumatic jacks and their pipes
- Battery
- Driver ventilation equipment

13.1.2) None of the above items may hinder cockpit exit or the driver's visibility.

13.1.3) The above components must be covered where necessary by a rigid protective material to minimise injury, and their mountings must be able to withstand 25 G deceleration.

13.2 Cockpit exit time

The driver, seated in his normal driving position, must be able to get out from the cockpit in 7 seconds through the driver's door and in 9 seconds through the passenger's door.

For the purposes of these tests, the driver must be wearing all normal driving equipment, the seat belts must be fastened, the steering wheel must be in place in the most inconvenient position, and the doors must be closed.

13.3 Test for helmet removal

With the driver seated in his normal driving position in the car with which he/she is entered, wearing a cervical collar appropriate to his/her size and with the seat harness tightened, a member of the medical service must demonstrate that the helmet which the driver will wear in the race can be removed from his head without bending his neck or spinal column.

ARTICLE 14 : SAFETY EQUIPMENT

14.1 Fire extinguishers

The use of the following products is prohibited: BCF, NAF

All cars must be equipped with an extinguishing system homologated by the FIA in accordance with Article 253-7.2, except as regards the means of triggering.

A means of triggering from the outside, possibly combined with the circuit breaker and operated by a single lever, must be present at the bottom of the windscreen on the left side.

It must be marked with a letter "E" in red inside a red-edged white circle at least 100 mm in diameter.

14.2 Safety belts

The wearing of two shoulder straps, one lap strap and two crotch straps is compulsory.

These straps must comply with FIA standard N°8853/98.
It is prohibited for the seat belts to be anchored to the seats or their supports.

14.3 Rear view mirrors

The car must be fitted with two rear view mirrors, one fitted on each side of the car, in order to give an efficient view to the rear. Each mirror must have a minimum area of 100 cm².

The Scrutineers must be assured through a practical demonstration that the driver, seated normally, can clearly see the vehicles following him.

To this end, the driver will be asked to identify letters or figures, 15 cm high and 10 cm wide, displayed at random on boards placed behind the car according to the following instructions:

- Height: Between 40 cm and 100 cm from the ground.
- Width: 2 m one side or the other of the longitudinal centreline of the car.
- 10 metres behind the centreline of the rear axle
- Position: of the car.

14.4 Seats and headrest

14.4.1) The driver's seat must be homologated by the FIA and not modified.

Energy-absorbing and non-flammable material must be situated around the driver's head.

If there is a cushion between the homologated seat and the occupant, the maximum thickness of this cushion is 50 mm.

If the original attachments or supports are changed, they must comply with the provisions of article 253-16.

14.4.2) All cars must be equipped with a headrest which cannot deflect more than 50 mm when a rearward force of 85 daN is applied. The headrest surface must not be less than 400 cm² and must be continuous and without protruding parts.

It must be positioned so that it is the first point of contact for the driver's helmet in the event of an impact projecting his head backwards when he is seated normally.

14.5 Master switch

The driver, when seated normally with the safety belt fastened and the steering wheel in place, must be able to cut off all the electrical circuits and stop the engine by means of a spark-proof master switch.

This switch must be clearly marked by a symbol showing a red spark in a white-edged blue triangle and be accessible by the driver with his safety belt fastened.

There must also be an exterior switch, which is capable of being operated from a distance.

This switch must be located at the lower part of the windscreen pillar on the left-hand side.

14.6 Towing eyes

Front and rear towing eyes must:

- either be rigid, made from steel, with no chance of breaking, have an inner diameter between 80 and 100 mm and be 5 mm thick (round section so as not to cut or damage the straps used by the marshals); or homologated (ex. straps);
- be securely fitted to the structures of the chassis by means of a rigid part made from metal (cable hoops are not permitted);
- be within the perimeter of the bodywork as viewed from above;
- be easily identifiable and painted in yellow, red or orange;
- allow the towing of a car stuck in a gravel bed.

ARTICLE 15 : SAFETY STRUCTURES

15.1 Safety cage

The safety cage must have no more than six mounting points, except if supplementary mounting points become necessary because of the use of the reinforcements shown on the following drawings of the current Appendix J. The safety cage must be certified or homologated by an ASN or homologated by the FIA and comprise the following elements :

- Main rollbar
- Front rollbar
- Lateral rollbar or lateral half-rollbar
- Two diagonal members in conformity with drawing 253-7. Members must be straight and one of the two must be a single piece.

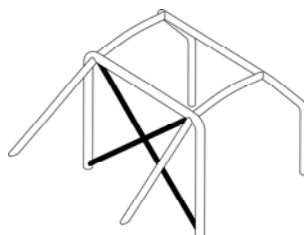

253-7

- Door struts, on each side, complying with drawings 253-9 or 253-10 or 253-11

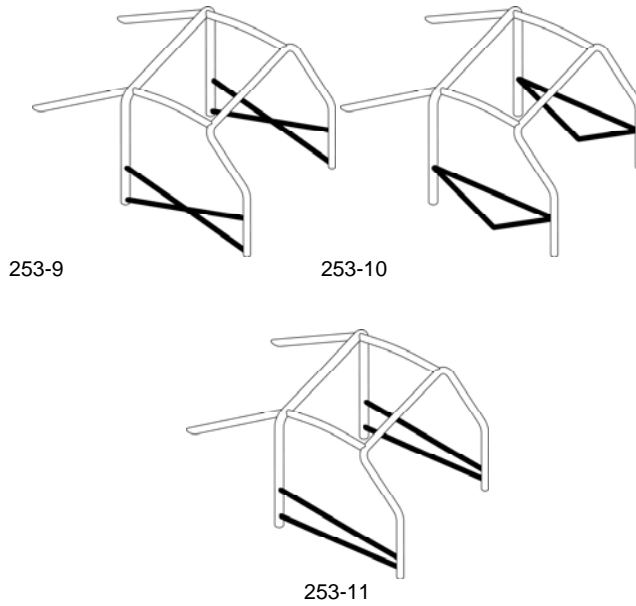

In the case of drawing 253-9 one of the two members must be a single piece.

- Windscreen pillar reinforcements, on each side, complying with drawing 253-15

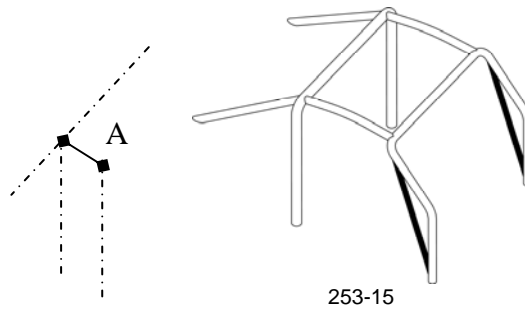

If dimension "A" (see drawing 253-15) is greater than 200 mm, a reinforcement member according to drawing 253-15 must be added on each side of the front rollbar between the upper corner of the windscreen and the base of this rollbar.

- Roof reinforcements

The upper part of the rollcage must be fitted with members according to one of the drawings 253-12, 253-13 and 253-14. In the case of drawing 253-12 one of the two members must be a single piece.

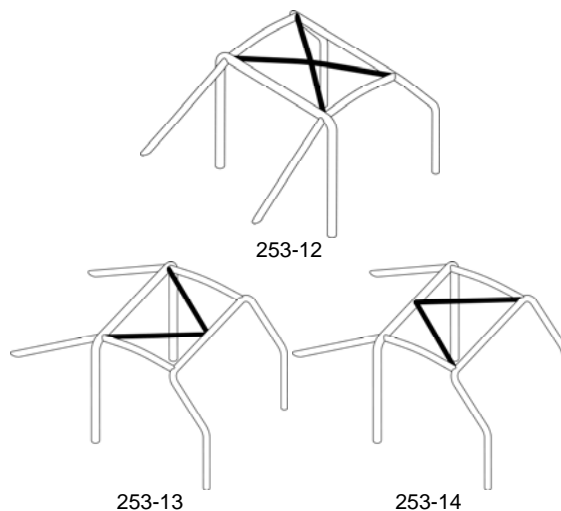

The reinforcements may follow the curve of the roof.

For competitions without co-drivers, in the case of drawing 253-12 only, one diagonal member only may be fitted but its front connection must be on the driver's side.

The ends of the reinforcements must be less than 100 mm from the junction between rollbars and members (not applicable to the top of the V formed by reinforcements in drawings 253-13 and 253-14).

- Two backstays

- Diagonal strut in conformity with drawing 253-4.

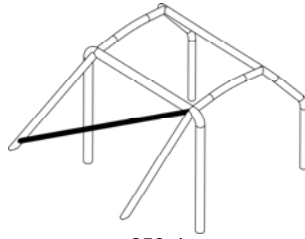

253-4

- Reinforcement of bends and junctions in conformity with drawing 253-31

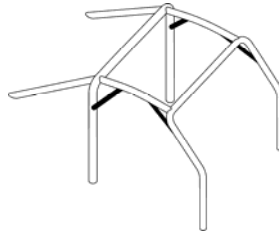

253-31

Minimum specifications of the tube used for the main rollbar must be :

- diameter 45 mm x thickness 2.5 mm (or 50 x 2 mm)
- tensile strength 350 N/mm².

It is possible to add three lateral protection bars in accordance with Drawing 258-4 onto a cage homologated by the FIA.

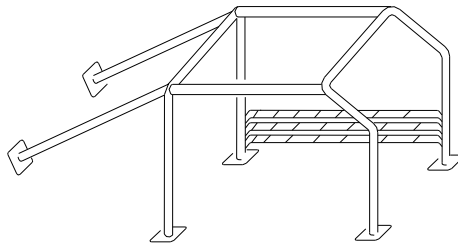

258-4

Reinforcements of junctions

The junctions between:

- the diagonal members of the main rollbar,
 - the roof reinforcements (configuration of drawing 253-12),
 - the doorbars (configuration of drawing 253-9),
 - the doorbars and the windscreen pillar reinforcement (drawing 253-15),
- must be reinforced by a minimum of 2 gussets complying with article 253-8.2.14 (drawing 253-34).

If the doorbars and the windscreen pillar reinforcement are not situated in the same plane, the reinforcement may be made of fabricated sheet metal, provided it complies with dimensions in article 253-8.2.14.

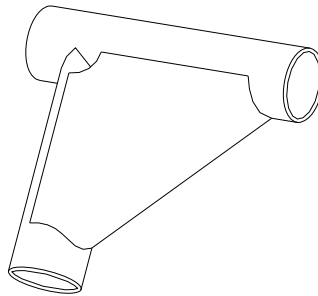

253-34

Not authorised

Front suspension mounting points (drawing 253-25) are not allowed.

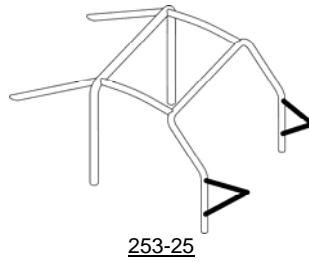

Protective padding

Where the occupants' bodies could come into contact with the safety cage, flame retardant padding must be provided for protection. Where the occupants' crash helmets could come into contact with the safety cage, the padding must comply with FIA standard 8857-2001, type A (see technical list n°23 "Roll Cage Padding Homologated by the FIA").

ARTICLE 16 : FUEL

16.1 Fuel specification

The fuel must comply with Article 252-9.1.

16.2 Air

Only air may be mixed with the fuel as an oxidant.

ARTICLE 17 : FINAL TEXT

The final text of these regulations is the English version, which shall be used should any dispute arise over their interpretation.

ARTICLE 18 : INBOARD CAMERA

A inboard camera system homologated by the DUTCH GT4 organisation is mandatory.

The installation of this system must be made in strict accordance with the corresponding instructions and must work at all times during the Event. All competitors are themselves responsible for obtaining the system, for the correct installation and the correct functioning thereof.



Goedgekeurd door KNAF / BSA op 1 april 2009.